

Operating Instructions (ETC-600)



Pre-use Inspection and Requirements for installation

- ◆ The power voltage should conform to the one marked on the controller and the voltage stability should be endured.
- ◆ The controller is forbidden to be used in water or over-moist environment and high temperature, powerful electromagnetic or high corrosive environment as well.
- ◆ **The sensor of the controller is USA DALLAS integrated temperature sensor, and please strictly stick to the instructions to connect the wire so as to avoid the sensor being damaged.**
- ◆ The pilot wire of the sensor should keep distanced from the power wire.
- ◆ The sensor's pilot wire, power wire and output relay socket should be clearly separated from one another and the current should not be overloaded.
- ◆ For the purpose of properly measuring the average temperature of the refrigerator and preventing the refrigerator from ending defrosting earlier, the sensor should be keep away from the vent hole and the heater for defrosting when installing it.

Specifications and Parameters

- ◆ Panel Size: 75 x 34.5 (Unit: mm)
- ◆ Fixing hole size: 30 x 71 (Unit: mm)
- ◆ Environmental Temperature: 0°C ~60°C
- ◆ Relative Humidity: 20% ~85% (Not allow to frost)
- ◆ Basic Technological Parameters:
 - ◇ Power Voltage: 220VAC(or 380VAC) ±10%, 50 ~60 HZ
 - ◇ Power: Less than 3W
 - ◇ Range: -40°C ~+110°C
 - ◇ Resolution: 0.1°C
 - ◇ Accuracy: -10°C ~+85°C, ±0.5°C, in other range less than ±2°C
 - ◇ Relay contact capacity: 7A/240VAC
- ◆ Main Functions:
 - ◇ Temperature measurement and control
 - ◇ Defrosting control
 - ◇ Forced refrigeration and defrosting
 - ◇ Compressor control
 - ◇ Compressor delayed time adjustable
 - ◇ Dual control of temperature and time when the defrosting course ends
 - ◇ The controller will start or stop working proportionally according to the sensor's error

Status of indicators

	Red lights	Compressor works normally
	Red flashes slowly	Compressor operation delayed
	Red flashes fast	Compressor forced to refrigerate (fast refrigeration)
	Red lights	Normally defrost
	Red flashes slowly	Adjust parameters
	Red flashes fast	Manually defrost (Forced to defrost)
	Red lights	Fan works normally
	Red flashes slow	Fan operation delayed after electrified and defrosted
	Red flashes fast	Drain defrosted water

Functions of Keys

- ◆ Under refrigerating mode
 - ◇ Key ▲ : Instantly press it, and it will show normal temperature after displaying upper limit temperature 2 seconds
 - ◇ Key ▼ : Instantly press it, and it will show normal temperature 2 seconds later after displaying bottom temperature and defrosting sensor's temperature as well
 - ◇ Key SET: (Under non-defrosting condition) Instantly press the key, it will show normal temperature after showing defrosting cycle and defrosting time each 2 seconds; (Under defrosting condition) Instantly press it, and it will show normal temperature after showing defrosting sensor's temperature and its ending time each 2 seconds. Constantly press the key more than 3 seconds, you can set the parameters.
 - ◇ Key ✳ : Instantly press it, it will show normal temperature after showing the temperature when the defrosting course ends and the time cost before defrosting each for 2 seconds. And constantly press the key more than 3 seconds, you can start or stop manual defrosting (forced defrosting).
 - ◇ SET + Key ✳ : At the same time pressing the two more than 3 seconds can start or stop the function of forced refrigeration (Start or stop fast refrigeration function)
 - ◇ ▲ ▼ : Simultaneously press the two keys can lock or unlock the keypad.

Definitions for operation

- ◆ Lock/unlock keypad:
 - When the controller is powered on, simultaneously press key ▲ + ▼ more than 3 seconds, LED will display "POF", which means the keypad has been locked and this time press any key will take no effect. The controller will display normal temperature after showing "POF" 2 seconds. And under locked condition simultaneously press ▼ + more than 3 seconds, LED will display normal temperature after showing "PON" 2 seconds and this time you can operate the keypad for checking or resetting any parameters.
- ◆ Parameter Adjustment
 - ◇ Under the condition the keypad unlocked, press SET more than 3 minutes, and the light flashes slowly, which means entering into the status of parameter setting, and this time it will show the code of parameter item, then press ▲ or ▼ to adjust parameter items F01, F02 etc.
 - ◇ After entering the status of parameter setting, press ✳ to show the latest parameters set, press or to change the parameters. Repress key SET, the changed parameters will flash 2 second for temporary storage, if the parameters are not changed, they will not flash. At the same time return to the original parameter item, when repress or to show the next parameter item, if you press , it will show the latest set parameters, and press ▼ or to set parameters, then press SET to temporarily store the changed parameters and return to the original parameter item. And doing it constantly can change all the parameters.
 - ◇ When all the parameters adjusted, press key SET more than 3 seconds to confirm it and return out of the parameter setting status back to the temperature measuring status. **If key SET is not pressed 3 seconds for confirmation after all the parameters being adjusted**, and there's no operation of the keypad, the system will automatically return from the parameter setting status and back to the temperature measuring status, **but the system will not store the reset parameters and continue to operate according to the original set parameters.**
- ◆ Main Functions Setting
 - ◇ Function of Refrigerating and Heating :
 - Under refrigeration mode, when the temperature of the refrigerator is higher than the upper temperature limit, it will start to refrigerate, and when the temperature of the refrigerator is lower than the bottom temperature limit, it will stop refrigerating. And when the refrigerator's sensor loses its function, press the preset proportionally set time to start or stop operating the compressor. When to start refrigerating, you can set delayed operation protection.

◇ Defrosting Function

1. When to defrost, start the defrosting function according to the preset defrosting cycle, when to end the process of defrosting is controlled by the temperature when the defrosting process ends together with the time cost for defrosting, and no whichever comes, the process of defrosting will end. No matter whether to start compressor when the process of defrosting ends, the control will always execute the process of defrosting and water dropping.

2. Defrosting function cancellation When the evaporator's temperature is high than the temperature when the process of defrosting ends, the defrosting time and cycle are zero; under the fast refrigeration condition, it will not execute the defrosting function.

◇ Fan's Control

The fan will work together with the compressor and they do not work when to controller is to defrost. The controller will not work when the controller is to execute defrosting and water dropping function. And when the evaporator's temperature is higher than the fan's temperature the time when it stops working, the fan also does not work.

Alarm Information

◆ Alarm for sensor's error

Under the condition of being electrified, when the refrigerator's sensor errors, LED will flash while displaying 444 together with the buzzer humming. When the defrosting sensor errors, LED alternatively displays 888 and the current temperature of the refrigerator as well together with the buzzer humming.

◆ Alarm and its muting when the temperature out of the limits

When the temperature measured is higher than the upper limit temperature plus the preset upper limit or the temperature measured is lower than the bottom limit temperature minus the preset bottom limit, the temperature measured flashes together with the buzzer humming. If the delayed time set is not zero, it will alarm when the delayed time ends.

◆ Alarm for out of the measuring range

When the temperature to be measured by the sensor is higher than 110°C or lower than -40°C, the controller will display HHH or LLL together with the buzzer humming.

◆ Alarm muting

Under the condition of alarm status, press any key to mute the alarming noise without change the LED displaying status.

◆ Delayed error alarm

When to set delayed alarm, if error occurs, the controller will not immediately alarm till the delayed time ends and then it will display errors and make alarming noise.

Parameter Information and setting range

These below are the parameters that can be changed.

Code	Meaning	Range	Unit	Plant Set
F01	Set upper limit	-39-+110	℃	-15
F02	Set bottom limit	-40-+109	℃	-20
F03	Set limited alarm figure	0-20	℃	10
F04	Fast refrigeration time	0-20	hour	4
F05	Compressor's operation delayed	0-20	Minute	3
F06	Defrosting interval (cycle)	0-99	hour	6
F07	Defrosting time	0-99	Minute	30

F08	Temperature when the defrosting process ends	-40-+50	℃	10
F09	Temperature when the fan stops working	-40-+50	℃	2

These below are the parameters that cannot be changed by the users.

Parameter	Fixed Figure	Unit
Adjust refrigerator's temperature	0	℃
Time for defrosting and water dropping	3	Minute
Fan's delayed operation after defrosting and being electrified	5	Minute
Limited temperature alarm delayed	20	Minute
Sensor error delayed	3	Minute
Compressor start working after refrigerator loses its function	20	Minute
Compressor stops working after refrigerator's sensor loses its function	30	Minute
Type of defrosting	Electrified	
Fan's working mode	Works or stops together with the compressor	
Mode selecting	Refrigeration mode	
Alarm code for the temperature out of the range	More than +110℃ HHH	
	Less than -40℃ LLL	

Wire connection plan

◆ Panel Picture:

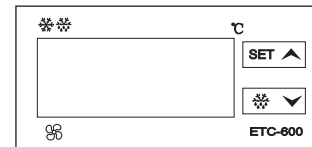

◆ Ends connection plan:

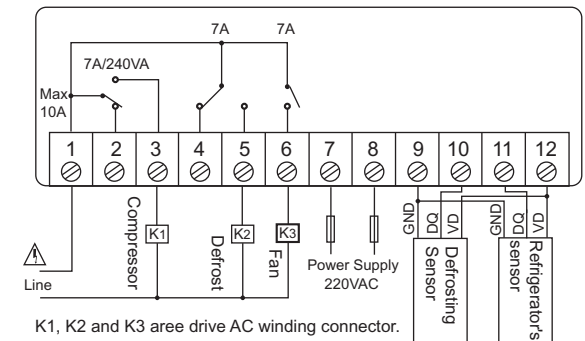

★ In refrigerator's pilot wire, the black one is connected with 9, the white with 11 and the red one with 12.

★ In defrosting sensor pilot wire, the black one is connected with 9, the white one with 10 and the red with 12.